



TECHNOTON

FUEL LEVEL SENSORS

DUT-E A5

DUT-E 232

DUT-E A10

DUT-E 485

DUT-E F

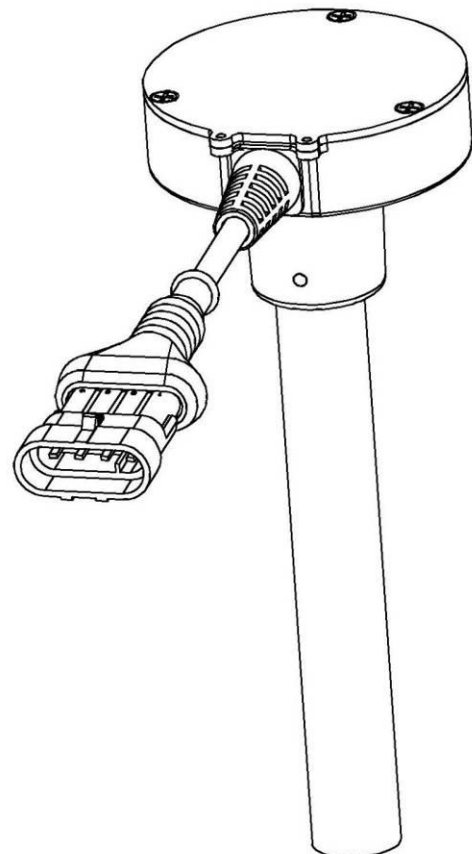
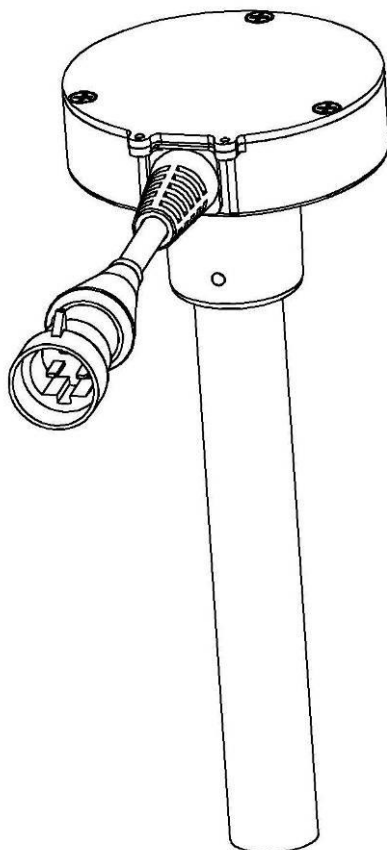

OPERATION MANUAL

Version 1.0

Content

Introduction.....	3
1. Main data and technical characteristics	5
1.1 Purpose of use.....	5
1.2 Exterior view and delivery set.....	5
1.3 Technical characteristics	6
1.3.1 Main characteristics	6
1.3.2 Characteristics of output signal for DUT-E A5 and DUT-E A10	6
1.3.3 Characteristics of output signal for DUT-E F.....	7
1.3.4 Characteristics of output signal for DUT-E 232 and DUT-E 485.....	8
1.4 Unit structure and principle of operation	9
1.5 Packing.....	10
2. Installation and set-up	11
2.1 Exterior examination before starting of works.....	11
2.2 Installation on the place of a standard fuel sensor.....	11
2.3 Installation into a special opening	11
2.4 Cutting of the measuring part for the necessary tank depth	15
2.5 Length increasing.....	15
2.6 Mounting	16
2.7 Electrical connection.....	17
2.8 Set-up of the analog or frequency DUT-E sensor.....	18
Setup and calibration of analog and frequency DUT-E is not required.	18
2.9 Set-up of the digital DUT-E sensor	18
2.10 Connection of DUT-E to the indicator of fuel level.....	20
2.11 Sealing	21
2.12 Measurement precision check	21
2.12.1 Basic issues	21
2.12.2 Control test steps	22
3. Diagnosis and troubleshooting.....	22
3.1 Diagnosis and troubleshooting of analog DUT-E	22
3.2 Diagnosis and troubleshooting of frequency DUT-E.....	23
3.3 Diagnosis and troubleshooting of digital DUT-E	23
4. Maintenance.....	23
4.1 General recommendation.....	23
4.2 De-mounting	24
4.3 Examination	24
4.4 Cleaning	24
5. Storage	25
6. Transportation.....	25
7. Utilization/re-cycling	25
Contact information	26
Appendix 1. Tank caibration.....	27
Appendix 2. Check-out test protocol	29
Appendix 3. DUT-E COM Protocol (Ver. 2.5)	30

Introduction

Recommendations and regulations given in the operation manual are referred to fuel level sensors DUT-E (hereinafter DUT-E), developed by the JV Technoton, Minsk, Belarus. This document defines the procedure for installation and connection of DUT-E, as well as provides guidance/recommendations on the operation.

DUT-E are used for accurate measurement of liquid fuel level in the vehicle tanks and in fixed/immovable tanks.

DUT-E can be used as a standard sensor of the fuel-level indicator, as well as in the fuel consumption control and vehicle monitoring systems.

Distinctive features of DUT-E:

- **delivery set includes all necessary items for the proper installation and connection**, incl. mounting plate, connecting cable, rubber gaskets, screws and seals;
- **supply voltage range is from 10 to 50 V**;
- **possibility to reduce the length up to 30% without calibration ***;
- **possibility to increase the length by using the additional sections of DUT-E**;
- **thermo-correction with adjustable coefficient** allows to make automatic updating of measurements based on the ambient temperature **;
- **easy bayonet fastening** allows you to install and remove the sensor without any tools;
- **bottom spring stop** serves to give extra stiffness for sensor mounting;
- **openings for sealing** will help to prevent the unauthorized demounting or operating troubles of DUT-E;
- **self-diagnostic check of DUT-E** allows to control the sensor operation.**

By using the DUT-E it is necessary strictly to follow the manufacturer's recommendations mentioned in this manual.

The manual is for the professional users who are familiar with the rules for repair and installation works on vehicles and who have professional knowledge in the field of electrical and electronic equipment of various transport vehicles.

To ensure the proper functioning of the DUT-E, its installation and set-up should be carried out by certified professionals trained by the manufacturer.

* DUT-E A5, DUT-E A10, DUT-E F

** DUT-E 232, DUT-E 485

DUT-E can be used in moderate and cold climates.

As for the mechanical stability sensors are vibration-shockproof and vibration-crashworthy.

Marking of sensors is formed as follows:

Fuel level sensor DUT-E X L=Y

Commercial name		Nominal length of the measuring part (in mm): - analog: 180, 250, 350, 500, 700, 1000, 1400, 2000; - frequency: 180, 250, 350, 500, 700, 1000, 1400; - digital: 700, 1000, 1400.
Type of sensor output signal: A5 – analog signal, voltage up to 4.5V; A10 – analog signal, voltage up to 9V; F – frequency signal, frequency up to 1500Hz; 232 – digital signal, interface RS-232; 485 – digital signal, interface RS-485.		

Manufacturer guarantees that the DUT-E sensor corresponds to the requirements of technical regulations provided that conditions of storage, transportation and maintenance as well as recommendations for use given in the manual to be followed.

To set up the digital DUT-E 232 and DUT-E 485 versions, Service kit SK DUT-E is applied. (not in delivery set and should be purchased separately).

1. Main data and technical characteristics

1.1 Purpose of use

Fuel level sensor DUT-E is designed to measure the level of liquid fuel and other non-electroconductive liquids in tanks of mobile vehicles and fixed/immovable tanks.

1.2 Exterior view and delivery set

DUT-E delivery set includes:

- a) sensor DUT-E in set – 1 pce;
- b) the bottom stop (for the sensors with a measuring part length of 500 mm or more) – 1 pce;
- c) signal cable 7 m - 1 pce;
- d) mounting plastic plate - 1 pce;
- e) rubber gasket for the mounting plate - 2 pcs;
- f) sealing O-ring plate - 2 pcs;
- g) self-drilling screw - 5 pcs;
- h) screw M5x16 - 5 pcs;
- i) seal - 2 pcs;
- j) sealing cord - 2 pcs;
- k) specification - 1 pce.



Fig.1. Delivery set of DUT-E

1.3 Technical characteristics

Power supply of DUT-E is carried out via on-board vehicle power system, on which it is installed.

1.3.1 Main characteristics

Table 1. DUT-E main characteristics

The relative measurement inaccuracy (to the length of the measuring part),%	±1
Supply voltage range, V	10 - 50
Current consumption , mA	≤50 at 12 V ≤25 at 24 V
Protection from pulse interferences , V	100
Readiness time after power-up, sec.	≤10
Temperature range, ° C	-40 ... +85
Protection level of housing	IP54
Length , mm	- analog: 180, 250, 350, 500, 700, 1000, 1400, 2000; - frequency: 180, 250, 350, 500, 700, 1000, 1400; - digital: 700, 1000, 1400.

1.3.2 Characteristics of output signal for DUT-E A5 and DUT-E A10

The voltage value of the DUT-E output signal has a linear dependence on the measured fuel level in the tank.

The output signal doesn't depend on supply voltage.

Table 2. Characteristics of output signal for DUT-E A5 and DUT-E A10

		Voltage, V	
		Nominal length	After cutting by 30%
DUT-E A5	Empty tank	1.5	0.65
	Full tank	4.5	2.65
DUT-E A10	Empty tank	2.5	0.65
	Full tank	9.0	5.30

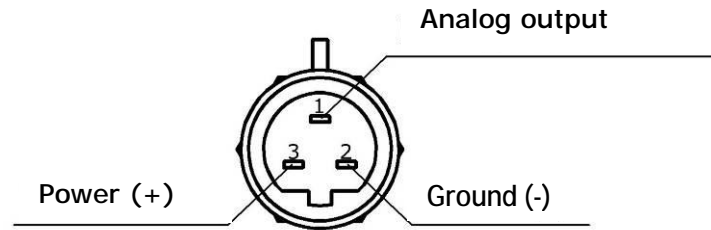

Fig.2. Connector diagram of DUT-E A5 and DUT-E A10

1.3.3 Characteristics of output signal for DUT-E F

The frequency value of the DUT-E output signal has a linear dependence on the measured fuel level in the tank.

The output signal doesn't depend on supply voltage.

Output cascade – open collector with load resistor 10 kOhm.

Table 3. Characteristics of output signal for DUT-E F

	Frequency, Hz	
	Nominal length	After cutting by 30%
Empty tank	500	270
Full tank	1500	970

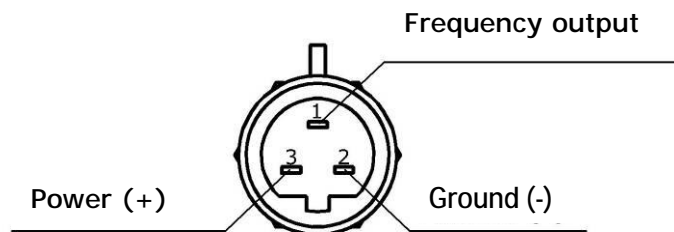

Fig.3. Connector diagram of DUT-E F

1.3.4 Characteristics of output signal for DUT-E 232 and DUT-E 485

Characteristics of output signal of DUT-E 232 and DUT-E 485 correspond to the specification of interfaces of RS-232 and RS-485 accordingly.

Factory interface settings: 19200 bit/s, 8bit, 1 stop bit.

Speed of data exchange via digital interface can be chosen from the following values: 4800, 9600, 19200 bit/s.

The results of DUT-E measurements can be transferred via digital interface as:

- a) Standard units, from 0 to 1000 (0-empty tank, 1000 - full tank);
- b) Fuel level in the tank, mm;
- c) Fuel volume, l;
- d) Fuel volume in relation to the full tank, %.

Besides the remaining fuel amount in the tank, DUT-E passes information about current temperature (measured by the sensor located on the electronic board).

Information transfer is carried out according to DUT-E COM protocol (See Appendix 3).

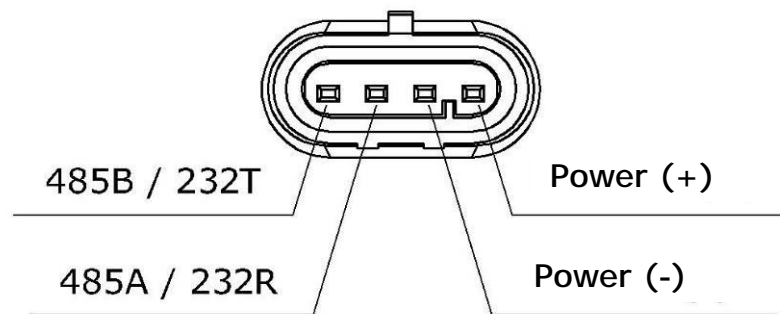

Fig. 4. Connector diagram of DUT-E 232 and DUT-E 485

1.4 Unit structure and principle of operation

DUT-E consists of: measuring part 1, which consists of two coaxially arranged aluminum tubes, housing with electronic board 2 and a signal cable 3 with the connector 4.

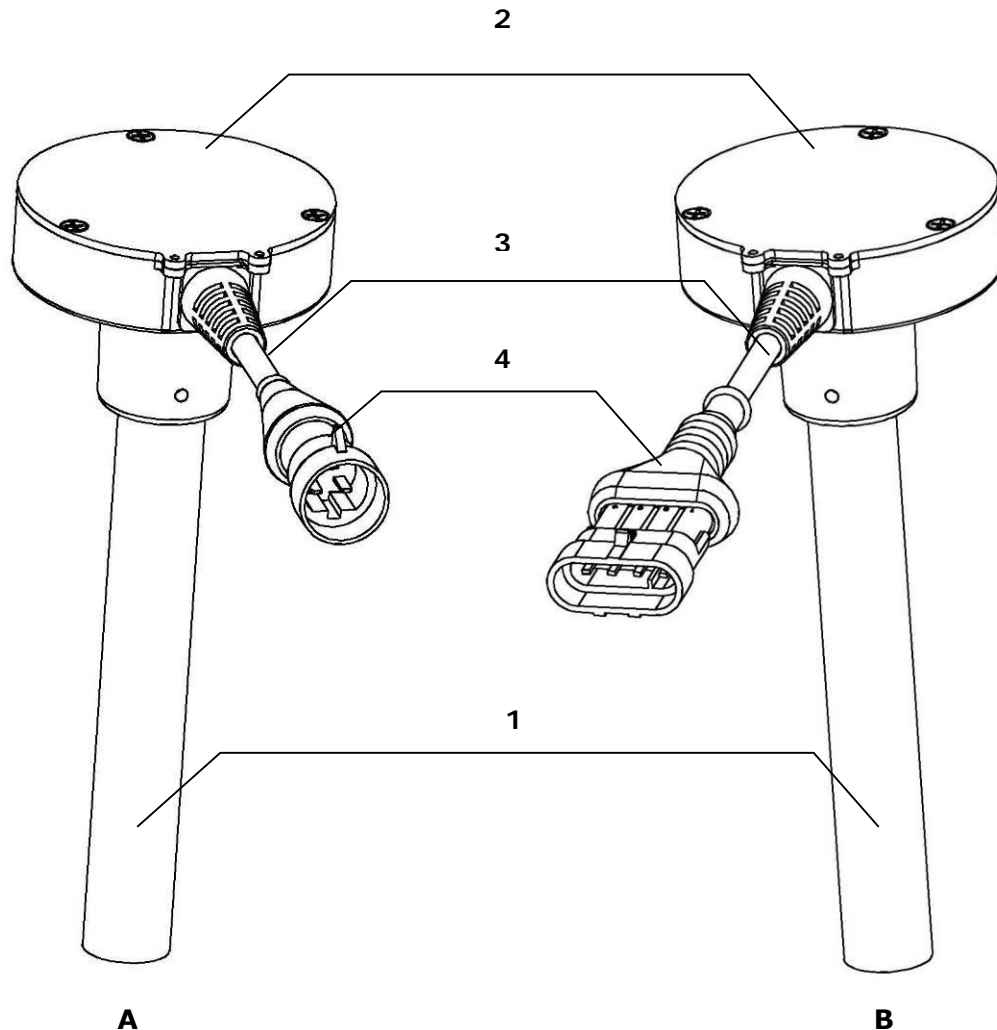

Fig. 5. DUT-E components

(A DUT-E A5, DUT-E A10 or DUT-E F; B DUT-E 232 or DUT-E 485)

DUT-E can be used together with the recording and display devices which have characteristics of input signals that correspond to output signals of DUT-E (See item 1.3).

The principle of the DUT-E operation is based on measurement of electric capacity of the condenser which is represented by tubes of the sensor measuring part. The electric capacity varies depending on the depth of its immersion into dielectric fluid. The electronic board of the sensor analyzes the current electric capacity value and generates a corresponding output signal.

Recalculation of the fuel level into the volume is carried out according to the calibration table. In order to make the calibration table it is necessary to calibrate the tank (See Appendix 1).

By using analog and frequency DUT-E sensors as a part of the transport monitoring system the volume calculation can be performed in the recording device (e.g., in the GPS-tracker), or in the software of the system itself.

Digital DUT-E are able to make calculation of the current fuel volume in the tank independently due to calibration table (See Appendix 1) which is put into the DUT-E memory by means of Service kit SK DUT-E.

1.5 Packing

DUT-E set is delivered in the carton box.



Fig.6. Packing of DUT-E

On one side of the box there is a sticker with information about the product, production date and factory control marks.

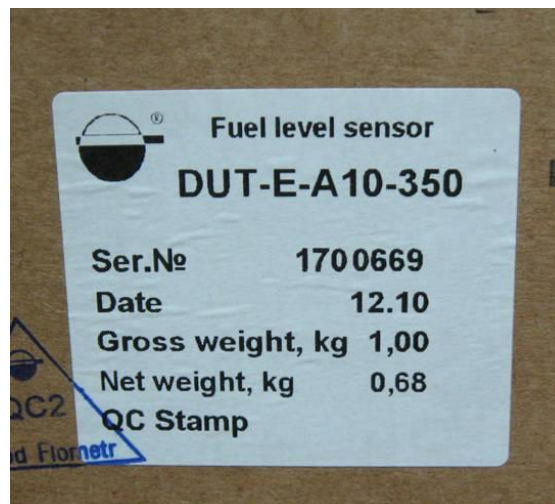

Fig.7. Sticker on the box with DUT-E

2. Installation and set-up

This chapter provides basic recommendations for the DUT-E installation. More detailed information is given in the installation manual for DUT-E.

2.1 Exterior examination before starting of works

Before you start, you should make external check of DUT-E for any possible defects that occurred during transportation, storage or careless handling:

- a) Visible damage of the housing, measuring part, mounting plate, rubber gaskets, signal cable or connector;
- b) Tube play of the measuring part in relation to each other and/or to the housing.

By discovering any defects, please, contact the product supplier.

DUT-E can be installed as into the opening of the *standard fuel sensor** as into a special opening in the tank.

** Study carefully the scheme of the mounting openings for the standard fuel sensor and compare with the DUT-E installation scheme (See Figure 9).*

ATTENTION! By installing the sensor you should follow safety rules when carrying out the repair works on automotive vehicles as well as safety requirements prescribed by the enterprise.

2.2 Installation on the place of a standard fuel sensor

ATTENTION! It is not recommended to install the DUT-E on the place of a standard fuel sensor because of its far location from the geometric center of the tank, and as a result, inaccuracy in the fuel level measurement may occur.

Before the DUT- E installation it is necessary to remove the standard fuel sensor and clean the installation place.

Align the holes of the mounting plate and rubber gasket with the holes in the tank.

For the installation you can use screws M5x16, that come together with the DUT-E set. Screw heads must be deeply put into the mounting plate.

2.3 Installation into a special opening

ATTENTION! Before drilling the holes in the tank you should dismantle it, evaporate or add water.

ATTENTION! Before you start drilling the hole, please, make sure that there are no partitions inside the tank under the selected location, what can prevent DUT-E installation.

Installation steps:

- a) Identify the place where it is supposed to install the sensor. It is recommended to choose a place in the geometric center of the tank as it will reduce the error of fuel volume measurement by its vibration during the movement;

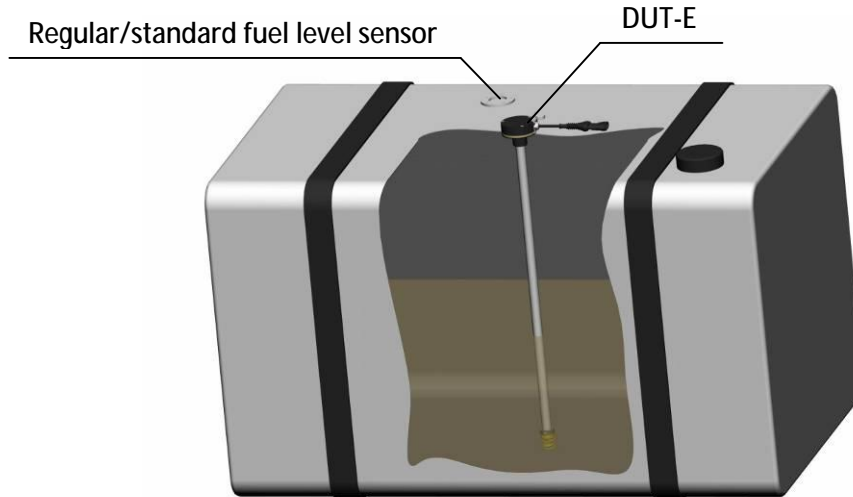

Fig.8. Recommended place for DUT-E installation

- b) Mark the place and drill the holes according to the following scheme (See Figure 9);

BE ATTENTIVE! Mounting plate can be installed only in one position! Prior to marking and drilling, please, study the place where it is supposed to install the plate so that holes for sealing were located in an accessible position.

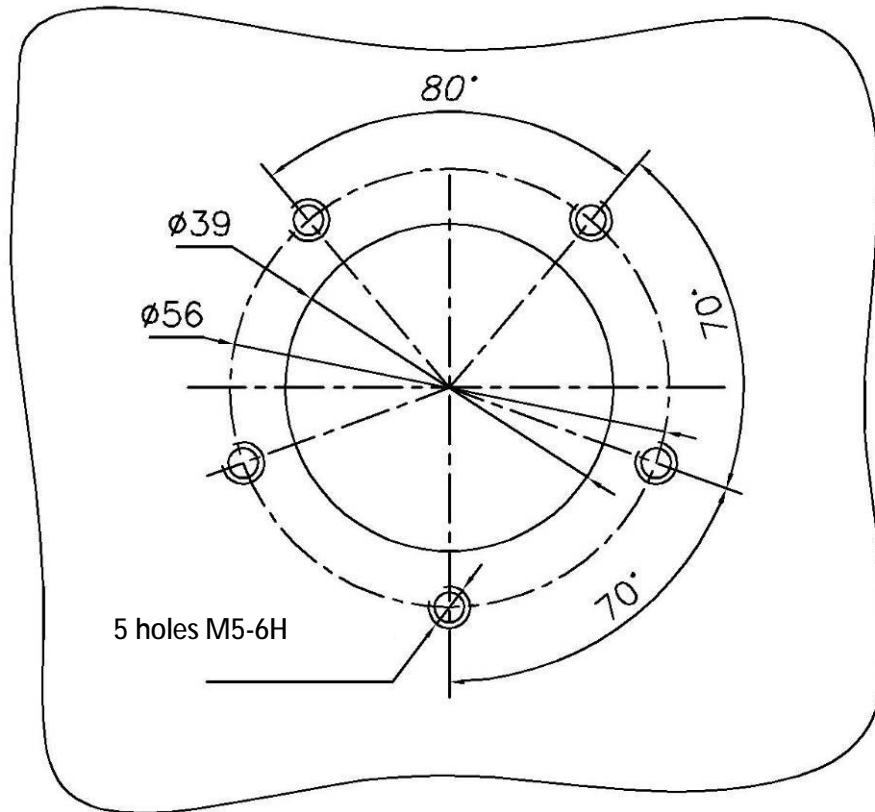

Fig. 9. Scheme of the holes for the mounting plate

- c) Put the gasket and mounting plate on the prepared hole, fix with screws or self-drilling screws that come in the delivery set.

ATTENTION! For the further sealing of the sensor it is recommended to put a sealing cord through the holes for sealing of the mounting plate prior to its installation on the fuel tank!

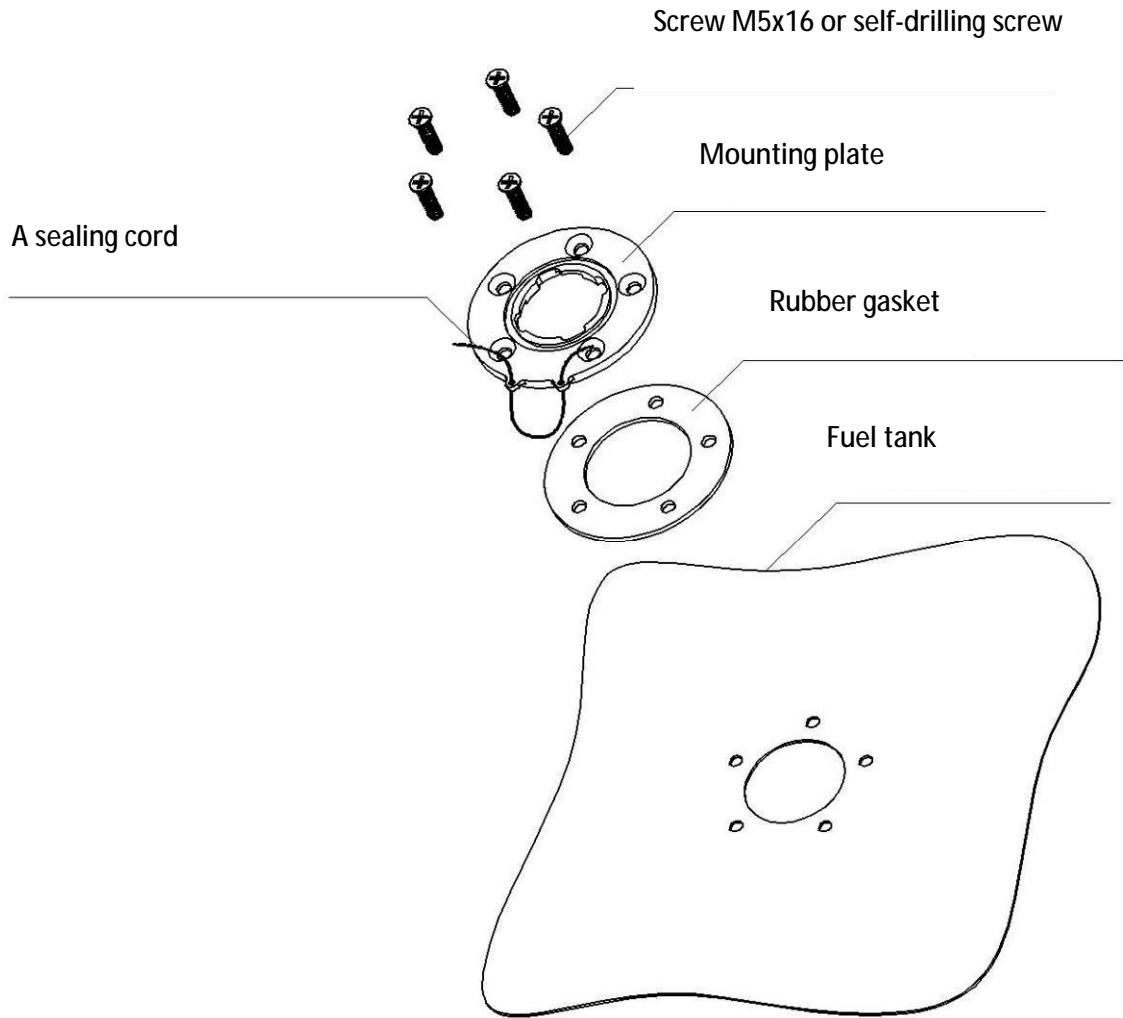

Fig. 10. Installation scheme of the mounting plate

ATTENTION! While attaching the plate to the tank, make sure, that the screw heads or self-drilling screw heads are not warped and deeply put into the mounting plate so that to provide electrical insulation of the vehicle tank casing from the DUT-E!

2.4 Cutting of the measuring part for the necessary tank depth

In order to avoid the short circuit of the measuring part tubes caused by water or electroconductive residues that are gathered on the bottom of the tank, there should be at least 2 cm gap between the tube end of the DUT-E measuring part and the bottom of the fuel tank.

ATTENTION!

For DUT-E A5, DUT-E A10, DUT-E F: allowed to make cutting up to 30% without further calibration;

For DUT-E 232, DUT-E 485: allowed to make cutting up to 70% with further calibration.

Steps by DUT-E cutting:

- a) Measure the depth from the mounting plate till the tank bottom;
- b) Cut the DUT-E measuring part based on the location of the tube end at a distance of 2-3 cm from the tank bottom;
- c) In case of DUT-E 232 or DUT-E 485 cutting you should calibrate the sensor using the Service kit SK DUT-E (See item 2.9).

ATTENTION! DUT-E cutting should be done by means of hacksaw or with a pipe cutter of a suitable diameter. Cutting edges should be thoroughly cleaned up and washed up with the fuel.

2.5 Length increasing

Length increasing is carried out by attaching of DUT-E additional section to the measuring part.

Model range of DUT-E additional sections include: KDC 250, KDC 500 and KDC 1000 with lengths of 250, 500 and 1000 mm correspondingly.



Fig. 11. Additional section of DUT-E

Length increasing of analog and frequency DUT-E sensors is possible **only** for restoring the length after cutting and **only** within limits of the DUT-E nominal length.

Length increasing for digital DUT-E sensor is allowed to a length of 6000 mm.

The detailed information for the mounting process is contained in the operation manual for DUT-E additional section.

Extra sections of DUT-E can be cut to the desired length. When cutting you should follow the recommendations given in item 2.4 of this guide.

2.6 Mounting

In order to fix the DUT-E it is necessary to put an O-ring right on the dap of the mounting plate, and then put the sensor into the hole, press it with force and lock by turning clockwise.

ATTENTION! During installation it is recommended to apply a small amount of oil or fuel on the O-ring of the mounting plate so that to prevent its deformation when you fix the DUT-E inside the mounting plate.

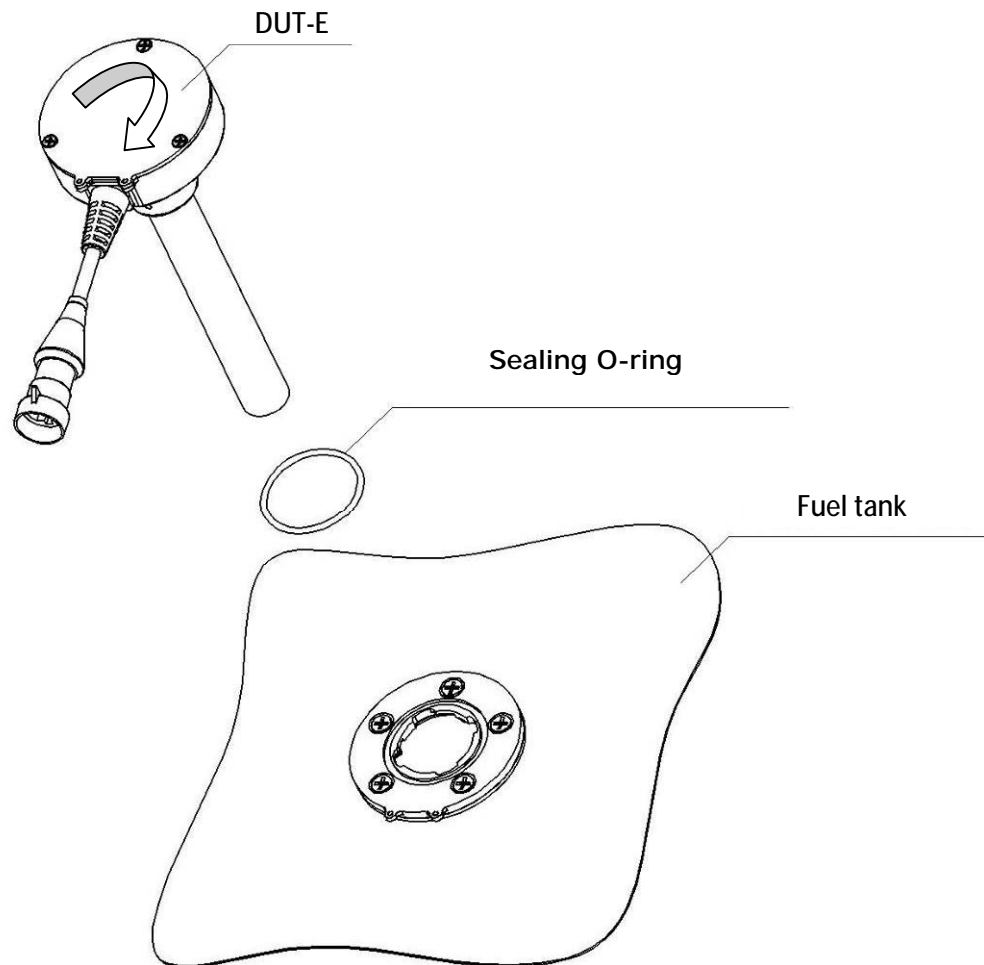

Fig.11. Installation scheme of DUT-E

Installation should be done in such a way that after the DUT-E mounting the sealing openings on the mounting plate and DUT-E housing were located under each other.

2.7 Electrical connection

The electrical connection of analog and frequency DUT-E is carried out in accordance with the following pin assignment (Figure 12, Table 4):

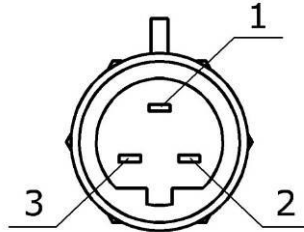

Fig. 12. Pins of analog and frequency DUT-E sensors

Table 4. Pin assignment of analog and frequency DUT-E

Pin No	Circuit name	Cable colour	Remark
1.	T701/T034	white	Analog or frequency output
2.	GND/T734	brown	"Ground" of the vehicle
3.	VBATT	orange	Power voltage

The electrical connection of digital DUT-E is carried out in accordance with the following pin assignment (Figure 13, Table 5).

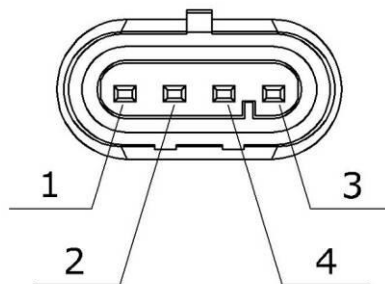

Fig. 13. Pins of digital DUT-E

Table 5. Pin assignment of digital DUT-E

Pin No	Circuit name	Cable colour	Remark
1.	VBAT	orange	Power voltage
2.	GND	brown	"Ground" of the vehicle
3.	232R/485A	white	Received data (RS 232) Data exchange (RS 485)
4.	232T/485B	red	Transferred data (RS 232) Data exchange (RS 485)

ATTENTION! Study thoroughly the textual wire tagging! The manufacturer keeps the right to change the colors of the wires.

The DUT-E housing is electrically connected with the "minus" of DUT-E (brown wire harness).

The mounting plate made of dielectric plastic material provides electrical insulation of the DUT-E casing from the vehicle casing (of the tank).

ATTENTION! Signal cable is **strongly recommended** to stack together with the standard wiring of the vehicle and **mandatory** to fix its position by means of tie-laps every 0.5-1 m.

During the set-up of the recording and display devices it is necessary to make a setting "DUT-E readings do not depend on the voltage of on-board power system" (if such setting available).

ATTENTION! Connection of the DUT-E to the on-board power system and "ground" is carried out in the same places where the recording and display devices are connected.

After installation and connection of DUT-E you should calibrate the tank vehicle (See Appendix 1).

2.8 Set-up of the analog or frequency DUT-E sensor

Setup and calibration of analog and frequency DUT-E is not required.

2.9 Set-up of the digital DUT-E sensor

For the proper operation of digital DUT-E it is required to make calibration with respect to the maximum and minimum fuel levels.

All DUT-E are delivered calibrated.

The calibration will be broken after the length cutting or increasing of digital DUT-E sensors.

Recalibration of DUT-E is carried out by means of "Service kit SK DUT-E" and "Service DUT-E" software (not in scope of supply and should be purchased separately).

The calibration process consists of the following procedures: to immerse the DUT-E measuring part into the fuel to a maximal point, to mark this value as the "maximum" and then completely pull out the measuring tube from the fuel with recording of the "minimum" value.

By means of the "Service DUT-E" software you can also set the desired DUT-E modes:

- Filtration time (default setting 10 s);
- Interval of periodic data output (default setting 1 s);
- Data output mode (default setting HEX) (See Figure 14).

Filtration time is the time period which is needed to count the average value of the fuel level. This setting is necessary to reduce the measurement inaccuracy of the fuel level by its vibrations in the vehicle tank.

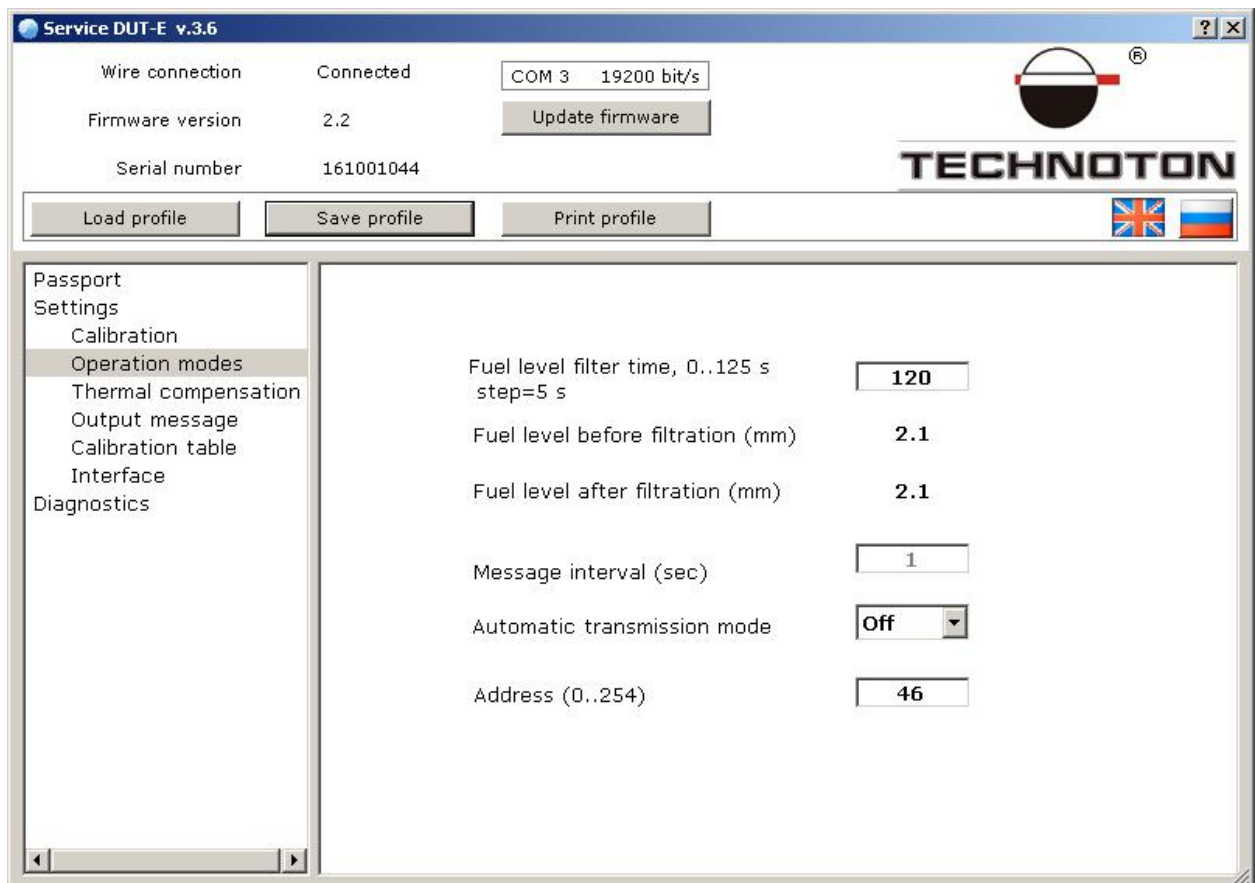

Fig. 14. Window of the software "Service DUT-E"

For the DUT-E 485 the setting of the unique address for each sensor in the network RS 485 is also available (See Figure 14).

2.10 Connection of DUT-E to the indicator of fuel level

By installing the DUT-E on the place of standard fuel level sensor you may need to control the needle indicator of remaining fuel in the tank. In order to implement this function you can use a special interface device developed by JV Technoton.

ATTENTION! Interface device complies only with DUT-E A5!

Table 6. Interface device models

Article order No	Remark
UC-1-90	Emulation of the level sensor with low resistance: 0-90 Ohm Resistance increases with increasing of the fuel level
UC-1-800	Emulation of the level sensor with high resistance: 800-185 Ohm Resistance decreases with increasing of the fuel level



Fig.15. Exterior view of the interface device UC-1

Table 7. Circuit name and wire colours:

Pin No	Circuit name	Wire colour*	Remark
1.	T034	white	Signal from the fuel level sensor (input)
2.	GND	brown	Vehicle ground
3.	T734	pink	Fuel level indicator (output)
4.	T733	pink	Control lamp of the fuel level (output)
5.	VBAT	orange	Power voltage

*The manufacturer reserves the right to change the wire colours.

2.11 Sealing

Sealing of the DUT-E is carried out by means of cord and disposable plastic seal (included in delivery set).

In order to seal the sensor you need to put the cord through the sealing holes of the mounting plate and DUT-E housing, after that put the free cord ends through two openings in the center of the seal. The cord will be fixed after the seal has been locked.

Separation of the seal without its breaking is not possible!

If necessary, you can use seals of other models and manufacturers.

ATTENTION! The cord of the seal shouldn't touch the tank!

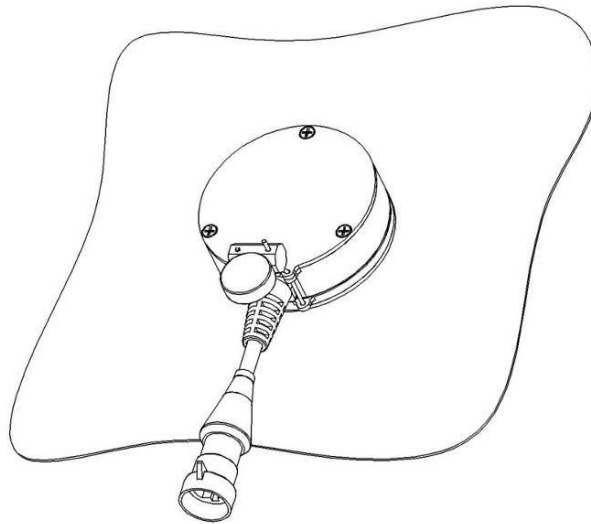

Fig.16. DUT-E sealing

2.12 Measurement precision check

All DUT-E are calibrated on diesel fuel by the manufacturer. In case of another type of fuel or another diesel fuel (the arctic type, with additional purification, etc.) you may need recalibration of DUT-E (digital) or making adjustments to the recording device.

2.12.1 Basic issues

Measurement precision check is needed to detect the relative and absolute measurement inaccuracy of DUT-E on the vehicle.

In order to check the measurement accuracy of DUT-E you should make control tests, i.e. to fill in and pour the fuel out from the tank, compare DUT-E readings with the actual filled-in/drained fuel.

Fuel discharging is done by manual or mechanical pump.

When you make tests, you should use the verified/tested containers to determine the volume capacity of the drained or filled-in fuel.

The volume of the filled-in/drained fuel should take at least 20% of the tank.

2.12.2 Control test steps

- a) Start up the ignition;
- b) Discharge the fuel of a certain volume;
- c) Determine the discharge volume with the help of the verified measuring device;
- d) Record the data into the protocol control tests (Appendix 2);
- e) Make a pause in order to stabilize the fuel in the tank (before stabilizing of DUT-E readings);
- f) Refuel the tank on the amount of the earlier drained fuel;
- g) Record the amount of the re-fuelling into the protocol;
- h) By analyzing the inaccuracy, the parameters "Drain" and "Refuel" are estimated in percentage relatively to the tank volume. Calculation formulas are given in Appendix 2.

3. Diagnosis and troubleshooting

If there are any failures during DUT-E operation, first of all, pay attention to electric wiring of the vehicle.

ATTENTION! Strong oxidation of the ground switch contacts or its failure can lead to a distortion of the DUT-E output signal.

ATTENTION! DUT-E indications will be incorrect if DUT-E tubes are closed with current-conductive dirt or water!

When you use the DUT-E, please, control the status of the power socket pins. If you detected contact oxidation or mechanical contact damage, contact the manufacturer or the service center to replace the connector.

3.1 Diagnosis and troubleshooting of analog DUT-E

The efficiency of the analog DUT-E can be checked with a voltmeter by means of measuring the output voltage and verifying it with the data from Table 8.

Table 8. Malfunction of analog DUT-E

Output voltage, V	Malfunction reason	Troubleshooting
From 0.65 to 4.6 for DUT-E A5 From 0.65 to 9.2 for DUT-E A10	No failures, normal operation	Check the recording and display devices
More than 4.6 for DUT-E A5 More than 9.2 for DUT-E A10	Tubes of the measuring part are "closed"; particles, dirt or water in the tank	Clean the DUT-E and the fuel tank of the vehicle
Less than 0.65 for DUT-E A5 and DUT-E A10	No contact of the measuring part with the electronic board; failures in the electronic board; cutting for more than 30%	Contact a regional service center

3.2 Diagnosis and troubleshooting of frequency DUT-E

Efficiency of the frequency DUT-E can be checked with a frequency meter by means of measuring the frequency of output signal and verifying it with the data from Table 9.

Table 9. Malfunction of frequency DUT-E

Output frequency, Hz	Malfunction reason	Troubleshooting
From 100 to 1600	No failures, normal operation	Check the recording and display devices
More than 1600	Tubes of the measuring part are "closed"; particles, dirt or water in the tank	Clean the DUT-E and the fuel tank of the vehicle
Less than 100	No contact of the measuring part with the electronic board; failures in the electronic board; cutting for more than 30%	Contact a regional service center

3.3 Diagnosis and troubleshooting of digital DUT-E

Efficiency of digital DUT-E is checked by connecting it to the DUT-E Service kit.

When any malfunction of the digital DUT-E occurs, an error code is transferred in the temperature field. Error codes are listed in Table 10.

Table 10. Malfunction of digital DUT-E

Error code	Description
255	Sensor is not calibrated
254	Sensor is not calibrated till maximum
253	Electrical interlocking of the sensor tubes
250,249	Another fuel type (i.e. not the one used by calibration) or dirt

4. Maintenance

4.1 General recommendation

External inspection and functional test are recommended to do at least 1 time per year.

ATTENTION! When remounting the DUT-E you should replace the O-ring of the mounting plate!

The DUT-E repair is carried out only by certified Regional Service Centers (hereafter RSC). Elimination of defects must be done when the electric power of DUT-E is switched off.

4.2 De-mounting

Before removing the DUT-E you should clean the surface of the tank near and around the place of the DUT-E installation.

Prepare a clean rag to remove any remaining fuel from the sensor, as well as provide protection from falling any rubbish or any debris into the tank through the mounting opening of the DUT-E with a cap (not in scope of supply and should be purchased separately).

Cut the sealing cord without damaging the signal wire.

Disconnect the DUT-E signal cable.

Undock DUT-E by turning the housing counterclockwise by 1 / 6 turn.

ATTENTION! When de-mounting the DUT-E, do not make any efforts to the signal cable. Otherwise, it is possible to damage the cable and / or an electronic board!

4.3 Examination

After the DUT-E has been de-mounted, it should be examined for possible defects:

- a) Visible damage to the electronic board, measuring part, mounting plate, signal cable or connector/pin;
- b) Tube play of the measuring part relatively to each other and / or housing;
- c) Presence of residues, incrustation, wax or any other debris between the tubes of the measuring part;
- d) Any leakages of fuel through the rubber gasket of the mounting plate.

If any defects discovered, please, apply to the Service Center or contact the manufacturer.

4.4 Cleaning

During the operation there can be incrustation, any deposits, residues or debris on the tube walls of the DUT-E measuring part.

Contamination of the cavity between the tubes of the DUT-E measuring part by any types of deposits leads to inaccuracy increase and failures in the DUT-E operation.

ATTENTION! Incrustation or sediments inside the central tube of the measuring part does not influence the efficiency and accuracy of DUT-E! You should control only the cleanness of the cavity between the two tubes of the measuring part.

Tubes of the DUT-E measuring part should be washed in the fuel which is used to measure the given DUT-E.

ATTENTION! During washing the tubes of the measuring part do not spill fuel on the DUT-E housing, the signal cable and/or its socket!

5. Storage

DUT-E is recommended to be stored in dry areas.

DUT-E storage is allowed only in original packaging at temperature range from -50 to +40 °C and relative humidity up to 100% at 25 °C.

Do not store DUT-E in the same room with substances that cause metal corrosion and/or contain aggressive impurities.

Storage life for DUT-E should not exceed 24 months.

6. Transportation

Transportation of DUT-E is recommended in closed transport that provides protection for DUT-E from mechanical damage and no access of precipitation.

During transportation by air the DUT-E must be placed in heated sealed compartments.

Air environment in vehicles should not contain acid, alkaline and other aggressive impurities.

Shipping containers with packed DUT-E sensors should be sealed.

7. Utilization/re-cycling

DUT-E does not contain harmful substances and ingredients that are dangerous to human health and environment during and after the end of life and recycling.

DUT-E does not contain precious metals in amount that should be recorded.

Contact information

Manufacturing plant

CJSC "Zavod Flometr"

222410, Republic of Belarus, Vileyka city, Chapaeva str., 26, room 101

Tel/fax: (+375 1771) 3-99-89

DEVELOPMENT, TECHNICAL SUPPORT

JV "Technoton"-CJSC

220033, Republic of Belarus, Minsk, Partizansky av. 2, dep. 4

Tel/fax: (+375 17) 298-07-04, 223-78-20; (+375 29) 159-60-61

E-mail: support@technoton.by

Additional information, addresses of official dealers and regional service centers are available at www.jv-technoton.com

Appendix 1. Tank calibration

The purpose of tank calibration is to find the dependence of the DUT-E output signal on the fuel volume in the tank.

In the process of calibration the tank is filled with fuel in accurately batched portions of 1/10 to 1/20 volume of the tank. The size and number of batches are determined by technical possibilities of the recording and display devices and geometric features of the tank.

For the measuring of fuel portions, please, use only verified measuring containers or fuelling nozzles of gas stations or mini-gas stations.

1. Conditions for tank calibration

Only people who have studied the operational manuals for DUT-E and for recording and display devices and who have experience with automotive electrical equipment can measure the tank.

During tank calibration process the below given technical requirements should be followed:

- a) Tank calibration can be performed only on the non-faulty vehicle;
- b) At the beginning of calibration procedure, the tank should be fueled for no more than 10% of the total volume;
- c) The tank calibration should be performed on a horizontal even surface. Vehicle loading should not be changed during the procedure;
- d) Wheels of the vehicle must be standard size;
- e) The tire pressure should correspond to the pressure set by the manufacturing factory for the given vehicle;
- f) The vehicle must remain motionless, ignition on, engine is stalled;
- g) Measuring containers and gas stations shall be verified and have inaccuracy of no more than 0.25%;
- h) Fuel batches should be filled into the tank sequentially with a pause of at least 0.5 minute.

2. Procedure of tank calibration

For a tank calibration the following procedures should be fulfilled:

- a) Empty the tank;
- b) Turn on the "ground" and the ignition;
- c) Make the following setting on the recording and display devices "DUT-E output signal does not depend on on-board voltage" (if such a setting available);
- d) Detect the value of the DUT-E output signal with help of recording and display devices;
- e) Record the initial fuel volume in the tank and value of the DUT-E output signal into the calibration table (See Table 1.1);
- f) Measure the earlier set portion of fuel with a measuring container and pour it into the tank;
- g) Wait until the DUT-E output signal indications stabilize (about 30-60 seconds);
- h) Record the fuel volume in the tank and indications of the DUT-E output signal into the calibration table (See Table 1);
- i) Pour the next fuel batch into the tank. DUT-E output signal begins to change;
- j) Fulfill items g) ... i) until complete filling of the tank;
- k) Put the calibration table into the recording and display device or into DUT-E memory (only for digital DUT-E).

Table 1.1. Calibration Table

Nº	Fuel volume in the tank, l	DUT-E output signal	Nº	Fuel volume in the tank, l	DUT-E output signal
1	Initial value		13		
2			14		
3			15		
4			16		
5			17		
6			18		
7			19		
8			20		
9			21		
10			22		
11			23		
12			24		

Appendix 2. Check-out test protocol

Dated "___" _____ 20___

Model and serial number of DUT-E	
Vehicle make, its model, registration plate	
Model, factory number of the recording and display device	

Discharge volume from the tank	Acc. to the batcher readings V_B, l	
	Acc. to the terminal readings V_{term}, l	
Inaccuracy of discharge measurement	absolute $\Delta = V_{term} - V_B, l$	
	relative to the tank volume of the vehicle $d = \frac{V_{term} - V_B}{V_{fuel\ tank}} \times 100\%, \%$	

Volume of fuel filling into the tank	Acc. to the batcher readings V_B, l	
	Acc. to the terminal readings V_{term}, l	
Inaccuracy of fuel filling measurement	absolute $\Delta = V_{term} - V_B, l$	
	relative to the tank volume of the vehicle $d = \frac{V_{term} - V_B}{V_{fuel\ tank}} \times 100\%, \%$	

Conclusions:

Result of the fuel filling measurement corresponds (doesn't correspond) to the technical requirements.

Result of the discharge measurement corresponds (doesn't correspond) to the technical requirements.

Remarks: _____

Customer representative _____ / _____ /

Contractor representative _____ / _____ /

Appendix 3. DUT-E COM Protocol (Ver. 2.5)

1. Purpose

This protocol is used during data exchange with digital fuel level sensors DUT-E 232 and DUT-E 485 (starting with the software version 1.13) developed by JV Technoton.

2. Model OSI

Table 1. Model OSI

Nº	Layer name	Layer description	Relation to the protocol
1.	Physical	Radio and wire communication equipment	ANSI/TIA-485-A & TIA/EIA 232-F ANSI/TIA-485-A & TIA/EIA 232-F
2.	Channel	Network interaction on physical level	
3.	Network	Rooting	
4.	Transport	Transportation without errors and losses	Transportation unit: message, check sum availability.
5.	Session	Making, support, termination of control session	Making the connection, authorization, termination of control session
6.	Presentation	Coding, compression	Parameter codes, message format
7.	Application	Service and operational info	Bidirectional transmission of information

3. Network layer

It is used to exchange messages over the RS-485 bus-line (or over data exchange lines TX and RX via interface RS-232). Only one device can be active on the bus-line, i.e. the idea "master-slave" is supported.

4. Transportation layer

Unit of data transmission is Message.

In general view Message consists of 3 parts:

- 1) Header;
- 2) Data bytes;
- 3) Checksum.

Table 2. Message structure

Header			Data bytes	Checksum
TypeID	Adr	Fmt	Data	CS
3 bytes			from 0 to 128 bytes	1 byte

4.1 Header

Software of the DUT-E fuel level sensors supports a packet header which consists of 3 bytes.

- TypeID - byte defines the type of sensor and direction of a packet transmission: query to the sensor or query answer;
- Adr - byte of the address receiver for the query or address of the reply message source.
- Fmt – byte of message format contains information about the message type and transmitted data.

4.1.1 Identifier of the sensor type (TypeID)

Table 3. List of possible values of byte TypeID

Значение TypeID	Sensor type and direction of message transmission
0x31	Fuel level sensor. Query to the sensor.
0x3e	Fuel level sensor. Response from the sensor.

4.1.2 Address (Adr)

Physical addressing is used. Address message receiver here is a physical address of the sensor to which the given message is sent.

The value of the address byte in range from 0 to 254 corresponds to physical sensors.

The value of the address byte 255 means sending a Message to all possible addresses.

The factory setting of the Address in DUT-E level sensors is the last 2 digits of a serial number.

4.1.3 Message format (Fmt)

The following byte values of message format are supported:
from 0x00 to 0x28.

List of message formats with description of the data fields shown in Table 7.

4.2 Data (Data bytes)

The data field may contain from 0 to 128 bytes of information. A detailed description of the data fields is contained in chapters 6 and 7.

4.3 Check sum (CS)

The checksum is calculated for all byte of the message (excluding the checksum) over a polynomial $a^8+a^5+a^4+1$.

For calculation of CRC you can use the following algorithms (language C):

1.

```
U8 CRC8(U8 data, U8 crc)
{
    U8 i = data ^ crc;
    crc = 0;
    if(i & 0x01) crc ^= 0x5e;
    if(i & 0x02) crc ^= 0xbc;
    if(i & 0x04) crc ^= 0x61;
    if(i & 0x08) crc ^= 0xc2;
    if(i & 0x10) crc ^= 0x9d;
    if(i & 0x20) crc ^= 0x23;
    if(i & 0x40) crc ^= 0x46;
    if(i & 0x80) crc ^= 0x8c;
    return crc;
}
```

2.

```
U8 CRC8 (U8 b, U8 crc)
{
    U8 i = 8;
    do {
        if ( (b ^ crc) & 0x01) {
            crc = ( (crc ^ 0x18) >> 1 ) | 0x80;
        } else {
            crc >>= 1;
        }
        b >>= 1;
    } while (--i);
    return crc;
}
```

3. Table method described in Dallas APPLICATION NOTE 27: Understanding and Using Cyclic Redundancy Checks with Dallas Semiconductor iButton Products.

5. Session layer, time intervals

Table 4. Marking of time intervals

Name	Description
P1	Interbyte interval for sensor response
P2	Time between the query and answer of the sensor
P3	Time between termination of the sensor response and beginning of the next request
P4	Interbyte interval for query

Table 5. Values of time intervals

Time intervals	Limit values, ms	
	minimal	maximal
P1	0	5
P2	0	300
P3	100	500
P4	0	5

6. Presentation layer. Transmitted data

Abbreviations used in the description of the transmitted data fields:

U8 - unsigned	8 bit value
S8 - signed	8 bit value
U16 - unsigned	16 bit value
S16 - signed	16 bit value
U32 - unsigned	32 bit value
S32 - signed	32 bit value

Table 6. Structure of the transmitted data

Nº	Structure name	Fields	Field description	Discreteness
1.	T_IDVU	U32	Serial number. To change it – a production level required	
2.	T_PARAMETR	S8 S16 U16	Temperature Transmitted parameter • fuel level (0..1000) • fuel level • fuel volume in the tank • fuel volume in the tank the current frequency of the oscillator	1 °C 1 unit 0.1 mm 0.1 l 0.4 % 1 Hz
3.	T_FILTR_LENG	U8	Filtering interval	5 s
4.	T_VERSION_SOFT	U8 dim[3]	Values of the firmware version	

7. Application layer

Table 7. Commands and answers

Nº	Command name	fmt	Action	Answer
1.	RD_SERIAL	0x02	Query for the sensor serial number	T_IDVU
2.	RD_PARAMETR	0x06	Request for the current sensor parameters	T_PARAMETR
3.	RD_FILT_LENG ²⁾	0x14	Read the value of the set interval filtering	T_FILTR_LENG
4.	RD_VERSION_SOFT ²⁾	0x1C	Read the current firmware version	T_VERSION_SOFT
5.	RD_PARAMETR_NOT FILTR ²⁾	0x1F	Request for the unfiltered current sensor parameters (similar to 0x06)	T_PARAMETR

²⁾ only for DUT-E with firmware, ver. 1.5 and higher.

8. Supported malfunction codes

DUT-E sensor passes the malfunction code to the temperature field in response to a query about the current parameters (RD_PARAMETR).

Table 8. Malfunction codes of DUT-E

Malfunction code value	Malfunction description
255	Sensor is not calibrated to the minimum or maximum (difference between the calibration frequencies of the measurement oscillator at minimum and maximum levels of fuel less than 100Hz)
254	Sensor is not calibrated to maximum of fuel level
253	The test oscillator is out of order in the sensor, possible the short circuit of the sensor measuring tubes (moreover, the fuel level is forcefully set up in 1000)
252	Calibration values for minimum and maximum fuel levels in the sensor differ by less than 5 Hz
251	Error EEPROM. Hardware failure of the sensor
250	The current frequency of the measurement oscillator is more than the set frequency by calibration for minimum (difference of more than 100 Hz)
249	The current frequency of the measurement oscillator is less than the set frequency by calibration for maximum (difference of more than 100 Hz)